

Agglomeration and demographic change

Theresa Grafeneder-Weissteiner*, Klaus Prettnner†

September 1, 2009

Abstract

This article investigates common consequences of population aging and economic integration for agglomeration. We introduce demography into the New Economic Geography by generalizing the constructed capital approach to account for finite planning horizons. Interestingly, the level of trade costs triggering agglomeration is rather sensitive to changes in mortality. In particular, we find that a positive mortality rate counteracts concentration of industrial activity. In sharp contrast to other New Economic Geography approaches, agglomeration processes may thus not set in even if economic integration is promoted up to a high degree.

JEL classification: F12; F15; C61

Keywords: Agglomeration; Constructed Capital Model; Population Aging

*Vienna University of Economics and Business Administration, Department of Economics, Augasse 2-6, A-1090 Vienna, Austria; email: tgrafene@wu-wien.ac.at; tel: +43 1 31336 4088; fax: +43 1 31336 9209

†Vienna Institute of Demography, Austrian Academy of Sciences, Wohllebengasse 12-14, A-1040, Vienna, Austria and Institute of Mathematical Methods in Economics, Vienna University of Technology, Argentinierstrasse 8/4/105-3, A-1040 Vienna, Austria; email: klaus.prettnner@oeaw.ac.at; tel: +43 1 51581 7729; fax: +43 1 51581 7730

1 Introduction

Over the last decades, most economies have been confronted with tremendous structural changes arising from globalization and demographic developments. Freer trade (see Sachs and Warner (1995)) has led to higher international integration meaning that goods produced in a certain region can nowadays be sold all over the world at a more competitive price. As a result, global competition for productive factors has emerged. In particular, firms have started to invest in regions where productive factors are relatively cheap and ship their goods to regions populated by consumers with high purchasing power. This emphasizes the linkage between relocation of manufacturing to areas with high rates of return on capital on the one hand and deeper economic integration on the other hand.

At the same time, fertility rates have decreased in nearly all countries (see Eurostat (2004)) resulting in lower population growth rates and aging societies (see United Nations (2007)). These demographic developments do not only change the productivity of labor but also have crucial impacts on the demand and saving patterns in the economy which in turn affect the returns of productive factors. As a consequence, economic integration and demographic change are inseparably linked with each other. Despite this fact, their common economic consequences have barely been analyzed in one single framework up to now. Our paper closes the gap by introducing demography into the New Economic Geography. We are thus able to describe the effects of declining transport costs on the location of productive factors in a setting with aging populations. In particular, our model reveals whether concentration of economic activity as emphasized by the New Economic Geography literature still takes place when allowing for finite planning horizons.

The New Economic Geography literature pioneered by Krugman (1991), Venables (1996) and Krugman and Venables (1995) provided new insights into how transport costs can determine the spatial distribution of economic activity. These models are characterized by catastrophic agglomeration meaning that for certain threshold levels of economic integration, industrial activity completely concentrates in one region. In particular, circular causality effects between factor rewards and demands for monopolistically competitive goods encourage agglomeration processes. They destabilize the

symmetric equilibrium with an equal division of productive factors and turn the core-periphery outcome with all industrial activity taking place in one region into a stable equilibrium. Reciprocal liberalization between initially symmetric regions that strengthens such circular causality effects thus leads to complete deindustrialization of one region.

Puga (1999) set up a model that nested as special cases both the Krugman (1991) framework with labor mobility between regions as well as the vertically linked-industries model of Venables (1996) and Krugman and Venables (1995) without interregional labor mobility. However, the richness of agglomeration features in these models reduced their analytical tractability. Therefore Baldwin (1999) introduced the constructed capital framework with interregional labor and capital immobility but forward-looking agents. His model features catastrophic agglomeration of capital stocks explained by the difference in the capital rental rates of two regions. A higher rental rate in the home region causes home capital accumulation, whereas capital is decumulated in the foreign region. The only force fostering this agglomeration process is a demand-linked circular causality effect setting in as a higher capital stock raises capital income and thus expenditures which leads to a further increase in home rental rates. Since neoclassical growth models in the spirit of Ramsey (1928) and Solow (1956) associate capital accumulation with medium-run growth, Baldwin (1999) describes the economy accumulating capital as a growth pole, whereas the other region appears as a growth sink. His agglomeration induced growth story therefore nicely illustrates how economic integration strengthening the demand-linked circular causality could lead to the development of “rust” and “boom belts”.

In contrast to the Ramsey (1928) framework of one single, infinitely lived, representative agent, on which the constructed capital model’s saving features heavily rely, agents do not live forever in reality. We therefore generalize Baldwin (1999)’s approach by introducing the possibility of death and thus accounting for finite planning horizons. In doing so, we adopt Blanchard (1985)’s structure of overlapping generations, where heterogeneity among individuals is due to their date of birth. While still following the lines of intertemporally optimizing agents, this results in a more comprehensive model incorporating life-cycle decisions and nesting the constructed capital set-up as a special case. Since demographic structures influence the saving patterns in the economy, the introduction of mortality affects the

capital rental rate and plays a crucial role for agglomeration processes. The model presented in this paper therefore reveals in detail the linkages between population aging, economic integration and agglomeration.

Our results show that the introduction of finite planning horizons weakens agglomeration tendencies between two regions. The possibility of death acts as an additional dispersion force against the concentration of industrial activity by lowering the positive effect of an increased capital stock on the capital rental rate. In particular, we find that a higher mortality rate considerably reduces the possibility of the symmetric equilibrium to be unstable. This implies that Baldwin (1999)'s agglomeration induced growth finding primarily applies in the very special case of infinitely lived individuals and that agglomeration processes in aging societies may not set in even if economic integration is promoted up to a high degree.

The paper proceeds as follows. Section 2 presents the structure of the model and derives optimal saving behavior and the equilibrium capital rental rate of the economy. Section 3 verifies the existence of a symmetric long-run equilibrium and characterizes its properties with respect to the mortality rate. Section 4 establishes the link between agglomeration and demographic change. To complement our analytical findings by numerical illustrations we also calibrate the model for reasonable parameter values. Finally, section 5 summarizes and draws conclusions for economic policy.

2 The model

This section describes how we integrate Blanchard (1985)'s notion of finite planning horizons into the constructed capital framework of Baldwin (1999). Consumption and savings behavior as well as production technologies are introduced and various intermediate findings resulting from profit maximization are presented. In order to be able to analyze the long-run equilibrium, we also derive aggregate laws of motion for capital and expenditures.

2.1 Basic structure and underlying assumptions

The model consists of two symmetric regions or countries, referred to as H for home and F for foreign¹, with identical production technologies, prefer-

¹If further distinction is needed, foreign variables are moreover indicated by an asterisk. In particular, the superscript F denotes that a good was *produced* in the foreign region,

ences of individuals, labor endowments and demographic structures. Each region has three economic sectors (agriculture, manufacturing and investment) with two immobile factors (labor L and capital K) at their disposal. The homogeneous agricultural good, n , is produced in a perfectly competitive market with labor as the only input and can be traded between the two regions without any cost. Manufacturing firms are modeled as in the monopolistic competition framework of Dixit and Stiglitz (1977) and therefore produce varieties, m , with one unit of capital as fixed input and labor as the variable production factor. A continuum of varieties $i \in (0, V_H]$ is produced at home, whereas a continuum of varieties $j \in (0, V_F]$ is manufactured in the foreign region. In contrast to the agricultural good, trade of manufactures involves iceberg transport costs such that $\varphi \geq 1$ units of the differentiated good have to be shipped in order to sell one unit abroad (see e.g. Baldwin et al. (2003)). In the Walrasian investment sector, capital, i.e. machines, are produced using labor as the only input where wages are paid out of the individuals' savings. The failure rate of a machine is assumed to be independent of the machine's age. Denoting this failure rate as $0 < \delta \leq 1$, and using the law of large numbers, implies that the overall depreciation rate of capital is given by δ as well.

As far as the demographic structure of our model economy is concerned, we closely follow Blanchard (1985)'s simplified setting. We assume that at each point in time, $\tau \in [0, \infty)$, a large cohort consisting of new individuals is born. These newborns receive no bequests and thus start their lives without any wealth. The size of this cohort is $N(\tau, \tau) = \mu N(\tau)$, where $0 < \mu \leq 1$ is the constant birth rate and $N(\tau) \equiv \int_{-\infty}^{\tau} N(t_0, \tau) dt_0$ is total population at time τ with $N(t_0, \tau)$ denoting the size of the cohort born at t_0 for any given point in time τ .² Consequently, cohorts can be distinguished by the birth date t_0 of their members. Since there is no heterogeneity between members of the same cohort, each cohort can be described by one representative individual, who inelastically supplies his efficiency units of labor at the labor market with perfect mobility across sectors but immobility between regions. The age of the individual is given by $a = \tau - t_0$ and his time of death is stochastic with an exponential probability density function. In particular,

whereas the asterisk indicates that it is *consumed* in the foreign region.

²In what follows the first time index of a variable will refer to the birth date, whereas the second will indicate a certain point in time.

the probability of death is also given by the age independent parameter μ resulting in a surviving probability to age $\tau - t_0$ of $e^{-\mu(\tau-t_0)}$. Since the population size is large, the frequency of dying is equal to the instantaneous mortality rate. Therefore the number of deaths at each point in time is $\mu N(\tau)$. As this equals, by assumption, the number of births, population size is constant and can be normalized to one. Finally, as in Yaari (1965), a perfect life-insurance company offers actuarial notes, which can be bought or sold by each individual and are canceled upon the individual's death.

2.2 Individual utility optimization

Preferences over the agricultural good and a CES composite of the manufacturing varieties are Cobb-Douglas.³ The representative individual of cohort t_0 chooses at each instant $\tau > t_0$ consumption of the agricultural good, $c_n(t_0, \tau)$, consumption of varieties produced at home, $c_m^H(i, t_0, \tau)$, and consumption of varieties produced abroad, $c_m^F(j, t_0, \tau)$, to maximize his expected lifetime utility at time t_0 ⁴

$$U(t_0, t_0) = \int_{t_0}^{\infty} e^{-(\rho+\mu)(\tau-t_0)} \ln \left[(c_n(t_0, \tau))^{1-\xi} (c_m^{agg}(t_0, \tau))^{\xi} \right] d\tau, \quad (1)$$

where $\rho > 0$ is the pure rate of time preference, $0 < \xi < 1$ is the manufacturing share of consumption and

$$c_m^{agg}(t_0, \tau) \equiv \left[\int_0^{V_H(\tau)} (c_m^H(i, t_0, \tau))^{\frac{\sigma-1}{\sigma}} di + \int_0^{V_F(\tau)} (c_m^F(j, t_0, \tau))^{\frac{\sigma-1}{\sigma}} dj \right]^{\frac{\sigma}{\sigma-1}}$$

represents consumption of the CES composite with $\sigma > 1$ denoting the elasticity of substitution between varieties.

Individual savings, defined as income minus consumption expenditures, are converted into capital in the investment sector with a time independent, exogenous labor input coefficient of F . The wealth constraint of a

³The following discussion refers to the home region but due to symmetry, equivalent equations also hold in the foreign region.

⁴Equation (1) can be easily derived by calculating expected lifetime utility where the date of death is a random variable with an exponential probability density function parameterized by a constant instantaneous mortality rate μ .

representative individual can be thus written as

$$\dot{k}(t_0, \tau) = \frac{w(\tau)l(\tau) + \pi(\tau)k(t_0, \tau) - e(t_0, \tau)}{w(\tau)F} + \mu k(t_0, \tau) - \delta k(t_0, \tau), \quad (2)$$

where $w(\tau)$ denotes the wage per efficiency unit of labor, $l(\tau)$ refers to the age independent efficiency units of labor an individual supplies, $\pi(\tau)$ is the capital rental rate, $k(t_0, \tau)$ the individual capital stock and $e(t_0, \tau)$ are individual total expenditures for consumption defined as

$$e(t_0, \tau) \equiv p_n(\tau)c_n(t_0, \tau) + \int_0^{V_H(\tau)} p_m^H(i, \tau)c_m^H(i, t_0, \tau)di + \int_0^{V_F(\tau)} p_{m,\varphi}^F(j, \tau)c_m^F(j, t_0, \tau)dj.$$

Here $p_n(\tau)$ is the price of the agricultural good, $p_m^H(i, \tau)$ the price of a manufactured variety produced at home and $p_{m,\varphi}^F(j, \tau)$ the price of a manufactured variety produced abroad with the subscript φ indicating the dependence on transport costs.

The particular law of motion for capital given in equation (2) is based on Yaari (1965)'s full insurance result implying that all individuals only hold their wealth in the form of actuarial notes.⁵ Therefore the market rate of return on capital, $\frac{\pi(\tau)}{w(\tau)F} - \delta$, has to be augmented by μ to obtain the fair rate on actuarial notes (see Yaari (1965)).

In appendix A we solve the individual's utility optimization problem by applying a three stage procedure. In the first stage the dynamic savings-expenditure decision is analyzed. Stage two deals with the static optimal consumption allocation between the CES composite and the agricultural good and in stage three individuals decide upon the amount of consumption they allocate to each of the manufactured varieties. Altogether this leads to the following demand functions for the agricultural good and for each of the

⁵Two interpretations of the capital accumulation process are therefore possible. Either each individual itself converts its savings into capital and then leaves it to the insurance company or savings are immediately transferred to the insurance company which converts them into machines by employing workers.

manufactured varieties

$$c_n(t_0, \tau) = \frac{(1 - \xi)e(t_0, \tau)}{p_n(\tau)}, \quad (3)$$

$$c_m^H(i, t_0, \tau) = \frac{\xi e(t_0, \tau)(p_m^H(i, \tau))^{-\sigma}}{\left[\int_0^{V_H(\tau)} (p_m^H(i, \tau))^{1-\sigma} di + \int_0^{V_F(\tau)} (p_{m,\varphi}^F(j, \tau))^{1-\sigma} dj \right]}, \quad (4)$$

$$c_m^F(j, t_0, \tau) = \frac{\xi e(t_0, \tau)(p_{m,\varphi}^F(j, \tau))^{-\sigma}}{\left[\int_0^{V_H(\tau)} (p_m^H(i, \tau))^{1-\sigma} di + \int_0^{V_F(\tau)} (p_{m,\varphi}^F(j, \tau))^{1-\sigma} dj \right]} \quad (5)$$

as well as to the consumption Euler equation for the representative individual of cohort t_0

$$\frac{\dot{e}(t_0, \tau)}{e(t_0, \tau)} = \frac{\pi(\tau)}{Fw(\tau)} - \delta - \rho. \quad (6)$$

As first shown by Yaari (1965) the representative individual's Euler equation with fully insured lifetime uncertainty is identical to the Euler equation when no lifetime uncertainty exists, i.e. individual saving behavior is not influenced by the mortality rate and moreover does not differ across generations.

2.3 Aggregate expenditures and capital

Due to the overlapping generations structure resulting from the introduction of mortality into the constructed capital framework, our model setup does not feature *one* single representative individual. In order to be able to analyze the long-run equilibrium of the economy as well as its stability properties it is therefore necessary to derive the aggregate law of motions of capital and consumption expenditures. The capital stock of the economy at a certain point in time t can be obtained by aggregating up the capital stocks of all cohorts. An analogous definition applies to consumption expenditures. These aggregation rules are formally given by

$$K(t) \equiv \int_{-\infty}^t k(t_0, t) N(t_0, t) dt_0, \quad (7)$$

$$E(t) \equiv \int_{-\infty}^t e(t_0, t) N(t_0, t) dt_0, \quad (8)$$

where $K(t)$ is the aggregate capital stock and $E(t)$ denotes aggregate consumption expenditures⁶. Equivalent equations hold for the foreign region.

Using the demographic assumptions described in section 2.1 we can exactly trace the size $N(t_0, t)$ of any particular cohort over time. A cohort born at time t_0 is of size $\mu e^{-\mu(t-t_0)}$ at time $t \geq t_0$ as the probability of surviving to time t equals $e^{-\mu(t-t_0)}$ and the initial size of the cohort is μ . Substituting for $N(t_0, t)$ in equation (8) therefore yields

$$E(t) \equiv \mu \int_{-\infty}^t e(t_0, t) e^{-\mu(t-t_0)} dt_0. \quad (9)$$

The “aggregate Euler equation”, modified for the existence of overlapping generations of finitely lived agents, directly follows from equation (9) by differentiating it with respect to t and then substituting for $\dot{e}(t_0, t)$ from the individual Euler equation (6) and for $e(t, t)$ and $E(t)$ from the corresponding expressions derived in appendix B where we describe the various aggregation steps in detail.⁷ It is given by

$$\frac{\dot{E}(t)}{E(t)} = -\mu(\rho + \mu)Fw(t)\frac{K(t)}{E(t)} + \frac{\pi(t)}{w(t)F} - \rho - \delta \quad (10)$$

$$= -\mu \frac{E(t) - e(t, t)}{E(t)} + \frac{\dot{e}(t_0, t)}{e(t_0, t)}. \quad (11)$$

In sharp contrast to the individual Euler equation, the mortality rate plays a prominent role in the aggregate Euler equation. From equation (11) it follows that the difference between individual and aggregate savings behavior is captured by a correction term representing the distributional effects due to the turnover of generations (see Heijdra and van der Ploeg (2002), chapter 16). Optimal consumption expenditure *growth* is the same for all generations (see equation (6)) but optimal expenditure *levels* differ. In particular, allowing for finite planning horizons introduces heterogeneity among individuals with respect to their birth dates and, since wealth and consumption levels are age dependent, also with respect to their expenditures. As shown in appendix B, optimal consumption expenditures $e(t_0, t)$ are propor-

⁶The aggregate efficiency units of labor $L(t)$ are equal to the individual supply of efficiency units of labor $l(t)$ due to age independency and the normalization of population size to one.

⁷Those aggregation steps closely follow the ones described by Heijdra and van der Ploeg (2002) in chapter 16.

tional to total wealth with the marginal propensity to consume out of total wealth being equal to the “effective” rate of time preference $\rho+\mu$. Older individuals are wealthier due to their accumulated capital holdings and therefore have higher consumption expenditure levels than their younger counterparts. Since dying old generations are replaced by newborns with no capital holdings at each point in time, *aggregate* consumption expenditure growth is smaller than *individual* consumption expenditure growth. The correction term on the right hand side of equation (10) therefore describes the difference between average consumption expenditures⁸ and consumption expenditures by newborns as shown in equation (11). Since $E(t) - e(t, t)$ is unambiguously positive (see appendix B), a higher mortality rate decreases aggregate consumption expenditure growth. This is intuitively clear as a higher μ implies a higher generational turnover and therefore a more pronounced (negative) distributional impact. In the case of infinitely lived individuals, i.e. $\mu = 0$, the turnover effect completely disappears. Since the mortality rate only enters the aggregate Euler equation via this turnover correction term, we can conclude that the introduction of finite planning horizons influences aggregate saving patterns in the economy only by the distributional effects resulting from the death. It is thus not surprising that this turnover channel will play a crucial role when it comes to investigating the linkage between the mortality rate and the forces fostering or weakening agglomeration in our model.

Similarly, the aggregate law of motion for the capital stock can be obtained. Rewriting equation (7) in analogy to equation (9) and then differentiating it with respect to t yields

$$\dot{K}(t) = \left[\frac{\pi(t)}{w(t)F} - \delta \right] K(t) + \frac{w(t)L(t)}{w(t)F} - \frac{E(t)}{w(t)F}, \quad (12)$$

where we applied the same steps as in the derivation for the aggregate Euler equation shown in appendix B.⁹ Compared to the law of motion for individual capital, there appears no term featuring the mortality rate μ . This captures the fact that $\mu K(t)$ does not represent aggregate capital accumulation but is a transfer - via the life insurance company - from individuals

⁸Since we normalized total population size to 1, total consumption expenditures $E(t)$ are equal to average consumption expenditures.

⁹In particular, we substituted for $k(t_0, t)$ from equation (2).

who died to those who survived within a given cohort. As a consequence, aggregate capital accumulates at a rate $\frac{\pi(t)}{w(t)F} - \delta$, whereas individual capital attracts the actuarial interest rate $\frac{\pi(t)}{w(t)F} + \mu - \delta$ for surviving individuals (see Heijdra and van der Ploeg (2002), chapter 16).

Summarizing, the mortality rate μ enters the law of motion for the individual capital stock but disappears in the corresponding aggregate law of motion. This is in sharp contrast to the Euler equation, where μ does not show up at the individual level but is part of the aggregate consumption expenditure growth rate.

2.4 Production technology and profit maximization

Profit maximization in the manufacturing and agricultural sector closely follows Baldwin (1999) and yields various intermediate results that simplify the subsequent analysis of the long-run equilibrium. In particular, the way the manufacturing sector is modeled allows us to derive the rental rate of capital as a function of home and foreign capital stocks and expenditures.

2.4.1 Agricultural sector

The homogeneous agricultural good, which can be interpreted as food, is produced according to the following constant returns to scale production function

$$Y_n(t) = \frac{1}{\alpha} L_n(t), \quad (13)$$

where $Y_n(t)$ denotes output of the agricultural sector, $L_n(t)$ represents aggregate labor devoted to agricultural production, and α is the unit input coefficient in the production of agricultural goods. Profit maximization under perfect competition implies that the price equals marginal costs. Moreover, by choice of units for agricultural output, α can be set to one implying that the wage rate equals the price of the agricultural good

$$p_n(t) = w_n(t). \quad (14)$$

Since labor is perfectly mobile across sectors the wage rate in the economy $w(t)$ satisfies

$$w_n(t) = w_m(t) = w_{inv}(t) = w(t), \quad (15)$$

where $w_n(t)$, $w_m(t)$ and $w_{inv}(t)$ denote wages in the agricultural, manufacturing and investment sector. Therefore equation (14) pins down the equilibrium wage in the economy. As free trade of the agricultural good between home and foreign equalizes its price, wages are also equalized between the two regions as long as each of them produces some $Y_n(t)$. This can be shown to hold if ξ , the manufacturing share of consumption, is not too large (see Baldwin (1999)) which will be assumed from now on. Finally, choosing the agricultural good as numeraire leads to

$$w(t) = w^*(t) = 1. \quad (16)$$

2.4.2 Manufacturing sector

Each firm in the Dixit and Stiglitz (1977) monopolistically competitive manufacturing sector produces a different output variety using labor as variable and one variety-specific machine as fixed input. This machine originates from the investment sector and is equivalent to one unit of capital. Due to the fixed costs, firms face an increasing returns to scale production technology with an associated cost function

$$\pi(t) + w(t)\beta Y_m(i, t), \quad (17)$$

where β is the unit input coefficient for efficiency units of labor, $Y_m(i, t)$ is total output of one manufacturing good producer and the capital rental rate $\pi(t)$ represents the fixed cost.

Defining¹⁰ $P_m(t) \equiv \int_0^{V_H(t)} (p_m^H(i, t))^{1-\sigma} di + \int_0^{V_F(t)} (p_{m,\varphi}^F(j, t))^{1-\sigma} dj$ and $P_m^*(t) \equiv \int_0^{V_F(t)} (p_m^H(j, t))^{1-\sigma} dj + \int_0^{V_H(t)} (p_{m,\varphi}^F(i, t))^{1-\sigma} di$ and recognizing that each individual firm has mass zero and hence does not influence the price indexes P_m and P_m^* , leads to the following maximization problem for each

¹⁰Note that $p_m^H(j, t) = p_m^{*F}(j, t)$ and $p_{m,\varphi}^F(i, t) = p_{m,\varphi}^{*H}(i, t)$ due to symmetry between the two regions, where $p_{m,\varphi}^{*H}(i, t)$ is the price of a good *produced* in the home economy but *consumed* in the foreign region.

firm at time t ¹¹

$$\begin{aligned}
& \max_{p_m^H, p_{m,\varphi}^F} && (p_m^H(i, t) - w(t)\beta) \left(\int_{-\infty}^t c_m^H(i, t_0, t) N(t_0, t) dt_0 \right) \\
& && + (p_{m,\varphi}^F(i, t) - w(t)\varphi\beta) \left(\int_{-\infty}^t c_m^{H*}(i, t_0, t) N^*(t_0, t) dt_0 \right) \\
& s.t. && c_m^H(i, t_0, t) = \frac{\xi e(t_0, t) (p_m^H(i, t))^{-\sigma}}{P_m(t)} \\
& && c_m^{H*}(i, t_0, t) = \frac{\xi e^*(t_0, t) (p_{m,\varphi}^F(i, t))^{-\sigma}}{P_m^*(t)}. \tag{18}
\end{aligned}$$

Carrying out the associated calculations shown in appendix C gives optimal prices

$$p_m^H(i, t) = \frac{\sigma}{\sigma - 1} w(t)\beta, \tag{19}$$

$$p_{m,\varphi}^F(i, t) = \frac{\sigma}{\sigma - 1} w(t)\beta\varphi. \tag{20}$$

Therefore the profit maximization problem yields the familiar rule that prices are equal to a constant markup over marginal costs which decreases in σ . This implies that a higher elasticity of substitution reduces the market power of manufacturing firms. Moreover, mill pricing is optimal, i.e. the only difference between prices in the two regions is due to transport costs (see Baldwin et al. (2003)).

Since we have variety specificity of capital and free entry into the manufacturing sector driving pure profits down to zero, the capital rental rate is equivalent to the Ricardian surplus, i.e. the operating profit of each manufacturing firm. In particular, the insurance companies, which hold all the capital due to the full insurance result (see section 2.2), rent their capital holdings to the manufacturing firms and can fully extract all profits. As shown in appendix C, using optimal prices given in equations (19) and (20) and redefining global quantities and regional share variables¹², gives oper-

¹¹We ignore fixed costs in the derivations here as they do not influence the first order conditions. Therefore we just maximize operating profit defined as revenues from selling the variety to the home and foreign region minus variable production costs (taking into account the effect of transport costs).

¹²In particular, note that the number of varieties in the home region $V_H(t)$ is equal to the capital stock at home $K(t)$ as one variety exactly requires one unit of capital as fixed input (analogously $K^*(t) \equiv V_F(t)$).

ating profits and thus capital rental rates as¹³

$$\pi = \underbrace{\left(\frac{\theta_E}{\theta_K + \phi(1 - \theta_K)} + \frac{(1 - \theta_E)\phi}{\phi\theta_K + 1 - \theta_K} \right)}_{Bias} \left(\frac{\xi E^W}{\sigma K^W} \right), \quad (21)$$

$$\pi^* = \underbrace{\left(\frac{1 - \theta_E}{1 - \theta_K + \phi\theta_K} + \frac{\theta_E\phi}{\phi(1 - \theta_K) + \theta_K} \right)}_{Bias^*} \left(\frac{\xi E^W}{\sigma K^W} \right), \quad (22)$$

where $\phi \equiv \varphi^{1-\sigma}$ is a measure of openness between the two regions with $\phi = 0$ indicating prohibitive trade barriers and $\phi = 1$ free trade. World expenditures are defined as $E^W \equiv E + E^*$ and the world capital stock as $K^W \equiv K + K^*$ with θ_K and θ_E being the respective home shares of these quantities, i.e. $\theta_K \equiv \frac{K}{K+K^*}$ and $\theta_E \equiv \frac{E}{E+E^*}$.

As expected, these rental rates are identical to those derived in Baldwin (1999)'s constructed capital model, since the introduction of mortality does not change the production side of the economy. In analogy to Baldwin (1999), the terms labeled *Bias* and *Bias** can be interpreted as the bias in national sales, i.e. *Bias* measures the extent to which a home variety's sales ($\sigma\pi$) differ from the world average sales per variety ($\frac{\xi E^W}{K^W}$). In the symmetric case with $\theta_K = 1/2$ and $\theta_E = 1/2$, $Bias = Bias^* = 1$ implying that operating profits of each manufacturing firm are given by $\frac{\xi E^W}{\sigma K^W}$, a result familiar from the monopolistic competition framework of Dixit and Stiglitz (1977). Additionally, *Bias* and *Bias** capture the impact of capital and expenditure shifting on profits.¹⁴ At the symmetric equilibrium, shifting expenditure to home ($d\theta_E > 0$) raises π and lowers π^* since it increases the home market size. A higher expenditure share therefore supports agglomeration of capital at home since capital accumulates where the rental rate is higher and decumulates in the other region. Production shifting¹⁵ to home ($d\theta_K > 0$), on the other hand, has the opposite impact as it increases competition in the home market. Both forces are crucial for explaining agglomeration processes

¹³We ignore time arguments here. Note, moreover, that $\xi = \xi^*$ and $\sigma = \sigma^*$ due to symmetry between regions.

¹⁴As capital is immobile between regions, the term capital shifting might be misleading. It should, however, only represent an exogenous perturbation of the home capital share (and similarly of the home expenditure share in the case of expenditure shifting).

¹⁵Recall that the number of varieties in the home region, $V_H(t)$, is equal to the capital stock at home, $K(t)$. This implies that capital accumulation in one region is tantamount to firm creation.

in Baldwin (1999)'s constructed capital model. In particular, suppose the two regions are in a symmetric equilibrium and capital stocks are slightly perturbed. If this perturbation raises the relative profitability in the region with the increased capital share then the equilibrium is unstable and agglomeration sets in. Whether catastrophic agglomeration of capital occurs is thus determined by the relative strength of the two effects described above. The local competition effect directly decreases the capital rental rate, whereas the higher expenditure share associated with a higher capital share indirectly increases the rate. This last channel is based on the demand-linked circular causality, i.e. a higher capital stock implies a higher income which increases expenditures and thus the capital rental rate. As both the pro-agglomerative expenditure shifting and the anti-agglomerative production shifting effect depend on the level of trade openness ϕ , the link between economic integration and agglomeration can be easily established. In this respect Baldwin (1999) shows that, when starting from a situation of prohibitive trade costs, agglomeration processes set in as soon as economic integration reaches a certain threshold level. The crucial question to be investigated in the following sections is whether similar agglomerative tendencies also appear in a setting with finite planning horizons of individuals.

3 Long-run equilibrium

The dynamics of this neoclassical growth model with overlapping generations are fully described by the following four dimensional system in the variables E , E^* , K and K^* whose equations were derived in section 2.3 and are given by¹⁶

$$\dot{K} = \left[\frac{\xi}{\sigma F} \left(\frac{E}{K + \phi K^*} + \frac{\phi E^*}{\phi K + K^*} \right) - \delta \right] K + \frac{L}{F} - \frac{E}{F}, \quad (23)$$

$$\dot{E} = -\mu(\rho + \mu)FK + E \left[\frac{\xi}{\sigma F} \left(\frac{E}{K + \phi K^*} + \frac{\phi E^*}{\phi K + K^*} \right) - \rho - \delta \right], \quad (24)$$

$$\dot{K}^* = \left[\frac{\xi}{\sigma F} \left(\frac{E^*}{K^* + \phi K} + \frac{\phi E}{\phi K^* + K} \right) - \delta \right] K^* + \frac{L}{F} - \frac{E^*}{F}, \quad (25)$$

$$\dot{E}^* = -\mu(\rho + \mu)FK^* + E^* \left[\frac{\xi}{\sigma F} \left(\frac{E^*}{K^* + \phi K} + \frac{\phi E}{\phi K^* + K} \right) - \rho - \delta \right]. \quad (26)$$

¹⁶We again suppress time arguments here.

Here we used that the equilibrium wage rate is equal to one in both regions and we already substituted for the rental rates from equations (21) and (22).¹⁷ The introduction of finite planning horizons affects the system only via the turnover correction term in the aggregate Euler equations, i.e. all effects of mortality hinge on the heterogeneity of wealth and therefore expenditure levels with respect to age. This again emphasizes the central role the generational turnover will play when investigating the model's dynamics with respect to the mortality rate. Moreover, setting $\mu = 0$, i.e. considering the case of an infinitely lived representative agent, reduces the law of motions to the ones obtained by Baldwin (1999). Our framework thus nests the constructed capital model as a special case.

A long-run equilibrium characterized by the steady-state values \bar{E} , \bar{K} , \bar{E}^* and \bar{K}^* must fulfill the system with the left hand side set equal to zero. It can be verified¹⁸ that the symmetric outcome with $K = K^*$ and $E = E^*$ has this property with the steady-state values given by¹⁹

$$\bar{E}_{sym} = \frac{L\sigma \left(\sigma\delta^2 + \rho\sigma\delta - 2\mu(\mu + \rho)(\sigma - \xi) + \delta\sqrt{\sigma}\sqrt{\sigma(\delta + \rho)^2 + 4\mu(\mu + \rho)\xi} \right)}{2(\delta\sigma + (\mu + \rho)(\sigma - \xi))(\delta\sigma + \mu(\xi - \sigma))}, \quad (27)$$

$$\bar{K}_{sym} = \frac{\delta L\sigma(\sigma + \xi) + L\sqrt{\sigma}(\sigma - \xi) \left(\rho\sqrt{\sigma} - \sqrt{\sigma(\delta + \rho)^2 + 4\mu(\mu + \rho)\xi} \right)}{2F(\delta\sigma + (\mu + \rho)(\sigma - \xi))(\delta\sigma + \mu(\xi - \sigma))}. \quad (28)$$

Investigating the dependence of these steady-state values of consumption expenditures and capital on the mortality rate gives deeper insight about the various ways the introduction of finite horizons impacts upon the model's behavior. There are two possible channels via which demographic change, as captured by variations in the mortality rate, can influence the steady state value of aggregate consumption expenditures. On the one hand, a higher mortality rate changes the age structure of the population by increasing the

¹⁷Note that we rewrote the rental rates as functions of the variables E , E^* , K and K^* and that, due to the assumption of symmetric regions, we have $L = L^*$ and $\mu = \mu^*$ as well as $F = F^*$, $\delta = \delta^*$ and $\rho = \rho^*$.

¹⁸These and most other results were derived with Mathematica. The corresponding files are available from the authors upon request.

¹⁹Solving the system for the symmetric equilibrium values in fact yielded two solution pairs. As one of them gives negative equilibrium expenditures for plausible parameter values we restrict our attention to the economically meaningful solution pair.

proportion of poor and young to wealthy and old individuals. As the former have lower expenditure levels, this first channel, which is closely connected to the turnover effect, indicates a negative dependence of equilibrium expenditures upon the mortality rate (“population structure based channel”). On the other hand, a higher mortality rate influences the savings behavior of individuals across all generations uniformly by changing their effective rate of time preference $\rho+\mu$ and thus their marginal propensity to consume out of total wealth (see section 2.3). According to this second channel, a higher mortality rate positively affects consumption expenditures since an increased probability of death resulting in a more heavy discounting of the future decreases saving incentives of all individuals (“saving behavior channel”). We can therefore conclude that the mortality rate’s effect on aggregate consumption expenditures is a priori ambiguous since it crucially depends on which of the two effects dominates.

However, as far as the aggregate equilibrium capital stock is concerned, both channels imply a negative dependence. First, a higher mortality rate decreases the proportion of old individuals with high capital stocks reducing the aggregate capital stock. Secondly, it increases the discount rate which implies lower savings and thus capital accumulation of all individuals.

To clarify the above arguing, we investigate the derivatives of \bar{E}_{sym} and \bar{K}_{sym} with respect to μ . As the corresponding signs are analytically ambiguous, we resort to numerical analysis by calibrating our model and evaluating the derivatives at the following plausible parameter values: $\mu = 0.0125$ resulting in a life expectancy of 80 years²⁰, $\delta = 0.05$ implying that capital depreciates on average after 20 years, $\rho = 0.015$ (see Auerbach and Kotlikoff (1987)), $F = 2$ by choice of units for the investment good and $L = 1$. Since there is considerable disagreement about the parameter values of σ and ξ , we use a wide range of their values in our numerical calculations. As far as the former is concerned, a plausible lower bound is $\sigma = 2$ as in Baldwin (1999). Most authors, however, use $\sigma \approx 4$ (see Krugman (1991), Krugman and Venables (1995), Martin and Ottaviano (1999), Puga (1999), Brakman et al. (2005) and Bosker and Garretsen (2007)). In order to consider all reasonable possibilities, we choose as an upper bound $\sigma = 8$. With respect to ξ , which in fact describes the share of consumption expenditures

²⁰Since the probability of death during each year equals 0.0125, average life expectancy is $\frac{1}{0.0125}$.

Figure 1: Derivative of \bar{E}_{sym} with respect to μ

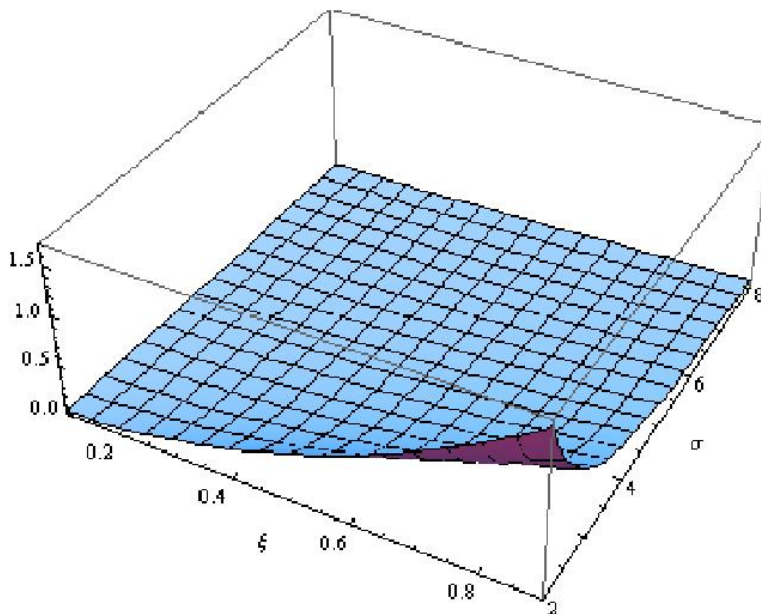

for the good produced under increasing returns to scale (relative to the good produced under constant returns to scale), Puga (1999), Head and Mayer (2003) and Bosker and Garretsen (2007) consider a value of $\xi = 0.1$, Krugman (1991) and Baldwin (1999) set $\xi = 0.3$, Krugman and Venables (1995) choose $\xi = 0.6$ and Martin and Ottaviano (1999) set $\xi = 0.8$. We therefore consider a possible parameter range of $0.1 \leq \xi \leq 0.9$ to account for this wide spread.²¹

Figure 1 and 2 reveal that for these parameter ranges the derivative of \bar{E}_{sym} with respect to μ is positive, whereas the derivative of \bar{K}_{sym} is negative.²² Consequently, a decrease in the mortality rate increases the aggregate equilibrium capital stock and decreases aggregate equilibrium expenditures. We can thus conclude that the mortality rate influences expenditures primarily via its positive effect on the discount rate. The saving behavior channel dominates the population structure one capturing the ef-

²¹Recall, however, that production of the agricultural good in both regions requires ξ to be sufficiently small (see section 2.4.1).

²²We also investigated the derivatives for varying mortality rates. Assuming $0.008 \leq \mu \leq 0.025$ resulting in a life expectancy between 40 and 120 years, and still considering the values for the other parameters mentioned before, does not change our findings.

Figure 2: Derivative of \bar{K}_{sym} with respect to μ

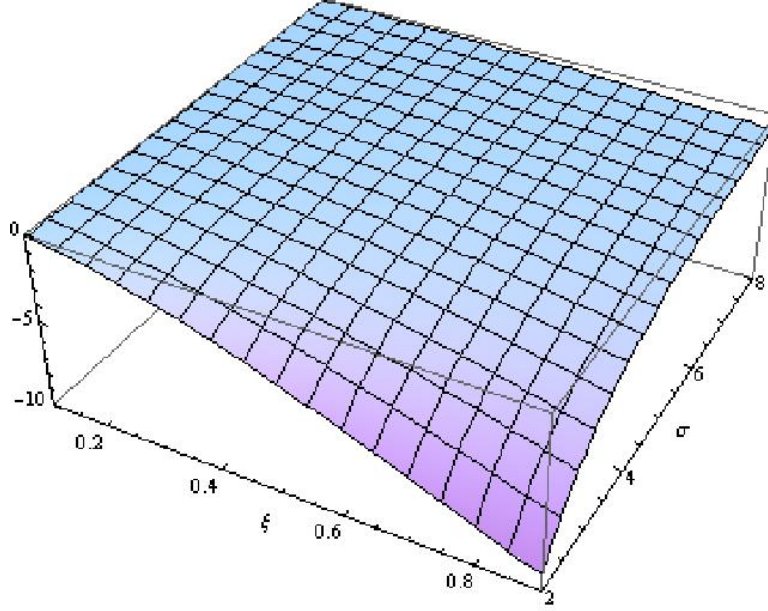

fects of the mortality rate on the age composition of the population and exerting its influence via the heterogeneity of expenditure and wealth levels with respect to age. The positive dependence of aggregate equilibrium expenditures on the mortality rate is fully consistent with the life cycle savings literature claiming that longer planning horizons, i.e. lower mortality rates, lead to higher individual savings and lower consumption levels (see e.g. Gertler (1999), Futagami and Nakajima (2001) or Zhang et al. (2003)).

As it turns out, when considering the impact of the mortality rate on the steady-state consumption expenditure share²³, $\frac{\bar{E}_{sym}}{\delta K_{sym} + \bar{E}_{sym}}$, even analytical results can be derived. This share is obtainable from the ratio of the equilibrium capital stock to the equilibrium expenditures²⁴

$$\frac{\bar{K}_{sym}}{\bar{E}_{sym}} = \frac{2\xi}{F(\delta\sigma + \rho\sigma + \sqrt{\sigma}\sqrt{\sigma(\delta + \rho)^2 + 4\mu(\mu + \rho)\xi})}, \quad (29)$$

²³This share is defined as equilibrium consumption expenditures divided by steady-state income, where steady-state income is the sum of replacement investment, δK (equal to savings in steady-state), and consumption expenditures.

²⁴Simply calculate $\frac{1}{\frac{\delta K_{sym}}{\bar{E}_{sym}} + 1}$.

which obviously depends negatively on the mortality rate. Consistent with our numerical findings, a higher mortality rate thus increases the steady-state consumption expenditure share which again supports the predominant role of the saving behavior channel.

4 Symmetric equilibrium *stability* - The impact of introducing mortality on agglomeration

New Economic Geography models emphasize that reciprocal liberalization between initially symmetric regions leads to catastrophic agglomeration, i.e. their main focus is on the instability of the symmetric equilibrium to be able to explain agglomeration processes between regions. In this section we show that the introduction of mortality considerably reduces the possibility of the symmetric equilibrium to be unstable. As a consequence, agglomeration of economic activity may not set in even if economic integration is promoted up to a high degree.

4.1 Formal stability analysis

The stability properties of the symmetric long-run equilibrium for varying trade costs and mortality rates are analyzed by following the classical approach (see Barro and Sala-i-Martin (2004)) of linearizing the non-linear dynamic system given in equations (23), (24), (25) and (26) around the symmetric equilibrium and then by evaluating the eigenvalues of the corresponding 4×4 Jacobian matrix

$$J_{sym} = \begin{pmatrix} J_1 & J_2 \\ J_3 & J_4 \end{pmatrix}, \quad (30)$$

where the four symmetric 2×2 sub-matrices J_i for $i = 1, \dots, 4$ are given in appendix D. Solving the characteristic equation yields the following four

eigenvalues

$$eig1 = \frac{1}{2}(r_1 - \sqrt{rad_1}), \quad (31)$$

$$eig2 = \frac{1}{2}(r_1 + \sqrt{rad_1}), \quad (32)$$

$$eig3 = \frac{1}{(\phi + 1)^2 \sqrt{\sigma}}(r_2 - \sqrt{rad_2}), \quad (33)$$

$$eig4 = \frac{1}{(\phi + 1)^2 \sqrt{\sigma}}(r_2 + \sqrt{rad_2}), \quad (34)$$

where

$$\begin{aligned} r_1 &\equiv \frac{A}{\sqrt{\sigma}} - \delta, \\ rad_1 &\equiv \left(\frac{A}{\sqrt{\sigma}} + \delta \right)^2 + \frac{(\sigma - \xi) \left((A + B)^2 + 4\mu(\mu + \rho)\xi \right)}{\sigma\xi}, \\ r_2 &\equiv 3\phi A + A - \sqrt{\sigma} \left(\delta(2\phi^2 + \phi + 1) + (\phi - 1)\phi\rho \right), \\ rad_2 &\equiv \frac{(A(\phi - 1) + (\delta(\phi - 1) + \phi(\phi + 3)\rho)\sqrt{\sigma})^2 + (\phi + 1)(\phi\sigma + \sigma + \phi\xi - \xi) \left((A + B)^2(\phi - 1)^2 + 4\mu(\phi + 1)^2(\mu + \rho)\xi \right)}{\xi}, \end{aligned}$$

with the parameter clusters $A \equiv \sqrt{\sigma(\delta + \rho)^2 + 4\mu(\mu + \rho)\xi}$ as well as $B \equiv (\delta + \rho)\sqrt{\sigma}$. The signs and nature of these eigenvalues fully characterize the system's local dynamics around the symmetric equilibrium. Analytically investigating them²⁵ thus results in lemma 1.

Lemma 1. *Eigenvalue 3 is decisive for the local stability properties of the symmetric equilibrium. A positive eigenvalue 3 implies instability, a negative one saddle path stability.*

Proof. By investigating the expressions for the eigenvalues it is first easily established that all of them are real. This holds since both rad_1 and rad_2 are nonnegative for all possible parameter values (in particular since $\sigma > \xi$).²⁶ Convergence to or divergence from the symmetric equilibrium is therefore monotonic.

As there are two jump variables E and E^* , saddle path stability prevails

²⁵In order to get a first idea about the signs and nature of the eigenvalues, we also calibrated the model and investigated the eigenvalues numerically. The corresponding findings are presented in appendix D.

²⁶Recall the parameter ranges $\sigma > 1$, $0 < \delta \leq 1$, $\rho > 0$, $0 < \mu \leq 1$, $0 < \xi < 1$ and $0 \leq \phi \leq 1$ which imply that $A > 0$ and $B > 0$.

if and only if there are two negative eigenvalues. If fewer than two eigenvalues are negative, the system is locally unstable. By inserting the expression for A , it turns out that $r_1 > 0$. We can thus immediately conclude that eigenvalue 2 is positive. In order to find out the sign of eigenvalue 1, we compare r_1 with the corresponding part under the radical, i.e. rad_1 . The square of the former is smaller than the latter, implying that eigenvalue 1 is always negative. It remains to investigate the signs of eigenvalues 3 and 4. Again we first check whether r_2 is nonnegative. By inserting the expression for A , r_2 can be rewritten as

$$r_2 = \underbrace{-\sqrt{\sigma}\delta(2\phi^2 + \phi + 1)}_{term1} + \underbrace{\sqrt{\sigma}(1 - \phi)\phi\rho}_{term2} + \underbrace{(1 + 3\phi)\sqrt{\sigma(\delta + \rho)^2 + 4\mu(\mu + \rho)\xi}}_{term3}. \quad (35)$$

All three terms are increasing in ρ , ξ and μ but react differently to changes in ϕ , δ and σ . In order to show that r_2 is nevertheless nonnegative for all parameter values we set ρ , ξ and μ equal to zero resulting in the “worst”, i.e. most negative, outcome with respect to these parameters. Since even in this case it is easily established that r_2 is nonnegative for the whole feasible parameter space the fourth eigenvalue is definitely positive. Summarizing, we have shown that eigenvalue 2 and 4 are always positive, whereas eigenvalue 1 is always negative. This proves the crucial role of the third eigenvalue as claimed in lemma 1. \square

Having demonstrated that changes in the parameter values, and in particular of the mortality rate, can only influence the stability properties of the symmetric equilibrium via eigenvalue 3, it is immediate to investigate this eigenvalue more thoroughly. Figure 3 plots eigenvalue 3 as a function of ϕ for three different mortality rates given our choice of the most plausible values of the other parameters ($\rho = 0.015$, $\delta = 0.05$, $\xi = 0.3$ and $\sigma = 4$). The graph indicates that, depending on the level of trade costs, eigenvalue 3 switches its sign.²⁷ Moreover, it is clearly visible that the range of ϕ within which eigenvalue 3 is positive, crucially depends on the mortality rate. This observation is investigated in the following proposition.

²⁷The numerical investigation of eigenvalue 3 in appendix D also reveals that it is impossible to come up with a definite sign for the whole parameter space.

Figure 3: **Eigenvalue 3 as a function of ϕ for $\mu = 0$ (dashed line), $\mu = 0.0002$ (solid line) and $\mu = 0.0004$ (dotted line)**

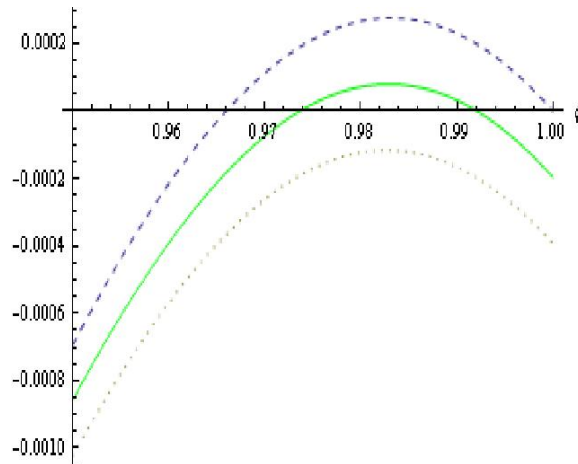

Proposition 1. *The sign of eigenvalue 3 and hence the stability properties of the symmetric equilibrium depend on the mortality rate.*

Proof. To prove this proposition, we use the concept of the critical level of trade costs ϕ_{break} . This threshold value identifies the degree of openness where eigenvalue 3 changes its sign and therefore where the stability properties of the symmetric equilibrium change (i.e. where eigenvalue 3 crosses the horizontal axis in figure 3). To analytically obtain ϕ_{break} , we set the expression for the third eigenvalue equal to zero and solve the resulting equation. This yields two solutions for ϕ_{break} as functions of the other parameters.²⁸ Since these two critical levels in particular also depend on the mortality rate (see again figure 3 for a graphical illustration), proposition 1 holds. \square

So far, we have shown that changes in the mortality rate influence the stability properties of the symmetric equilibrium. Figure 3 moreover already indicates the particular direction of the impact by illustrating that eigenvalue 3 decreases in the mortality rate. The next section is dedicated to investigating this relationship between aging and the stability properties of the symmetric equilibrium in more detail.

²⁸As the expressions are rather cumbersome they are not presented here but available upon request.

4.2 The impact of mortality on agglomeration

The effects of aging on agglomeration can be best understood by investigating eigenvalue 3 for varying trade costs and mortality rates. Figure 4 plotting the contour lines of eigenvalue 3 for varying μ and ϕ given our choice of the most plausible values of the other parameters ($\rho = 0.015$, $\delta = 0.05$, $\xi = 0.3$ and $\sigma = 4$) illustrates that there only exists a very small range of combinations of μ and ϕ where the sign of the third eigenvalue is positive. This instability region is characterized by parameter combinations inside the

Figure 4: Contour plot of eigenvalue 3

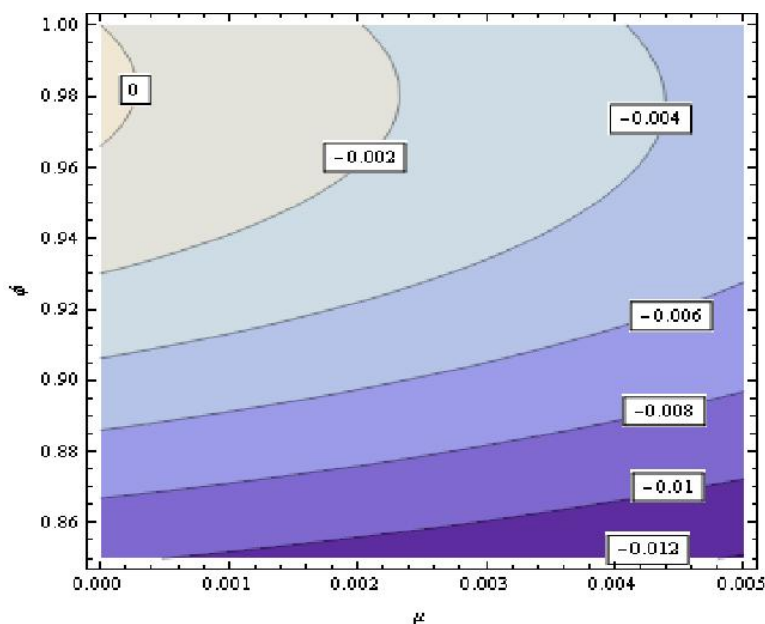

contour line=0 which yield a nonnegative eigenvalue 3. A higher mortality rate decreases eigenvalue 3 rather quickly for all levels of trade costs. Only in case of an (implausibly) low mortality rate it is possible to find critical values of transport costs within which the symmetric equilibrium becomes unstable and agglomeration processes can set in. We can therefore conclude that the introduction of finitely lived individuals profoundly reduces agglomeration tendencies. In particular, a higher mortality rate implies a smaller instability region with respect to the level of economic integration and thus increasingly prevents the two regions from unequal development.

The “smallness” of the instability region²⁹ moreover implies that, in sharp contrast to other New Economic Geography frameworks and in particular to Baldwin (1999)’s catastrophic agglomeration result, our model predicts the symmetric outcome to be predominant even in the presence of high economic integration.

The effects of aging on agglomeration are confirmed by investigating how the critical levels of trade costs react to changes in the mortality rate. Without mortality, i.e. $\mu = 0$, and again applying our choice of the most plausible parameter values, the two critical levels of trade costs are $\phi_{break1} = 0.965974$ and $\phi_{break2} = 1$.³⁰ In between those values, i.e. for sufficiently low levels of trade costs, the symmetric equilibrium is unstable and agglomeration processes do set in. Allowing μ to increase, however, shows that ϕ_{break1} increases, while ϕ_{break2} decreases. The range of trade cost levels within which the symmetric equilibrium is unstable clearly shrinks (in figure 3 this shrinkage is equivalently represented by the downward shift of eigenvalue 3). Figure 5 illustrates this finding by plotting the the two critical levels of trade costs for varying mortality rates as boundaries of the shaded instability region. In particular, we can establish that for $\mu = 0.00028$, corresponding to a life expectancy of less than approximately 3500 years, there exists no level of trade costs such that the symmetric equilibrium is unstable (i.e. the downward shift in figure 3 is such that eigenvalue 3 does not cross the horizontal axis anymore where it would become positive).³¹ Assuming reasonable values of the mortality rate therefore implies that, again in sharp contrast to other New Economic Geography models, deeper economic integration does *not* result in agglomeration processes. We can thus also conclude that Baldwin (1999)’s agglomeration induced growth finding primarily applies in the very special case of infinitely lived individuals.

Figure 5 does not only show that the instability region shrinks in the

²⁹Note that we plot this figure only for $\mu \leq 0.005$ and $\phi \geq 0.85$ which indicates how small the instability region relative to the whole parameter range is.

³⁰When calibrating our model with the parameter values assumed by Baldwin (1999), i.e. $\rho = \delta = 0.1$, $\xi = 0.3$ and $\sigma = 2$, the two critical levels of trade costs exactly coincide with Baldwin (1999)’s and are given by $\phi_{break1} = 0.860465$ and $\phi_{break2} = 1$.

³¹We also performed these simulations with respect to the critical level of trade costs for other parameter ranges, in particular for Baldwin (1999)’s parameter choice $\rho = \delta = 0.1$, $\xi = 0.3$ and $\sigma = 2$. In this case the critical mortality rate, above which the symmetric equilibrium is always stable, is given by $\mu > 0.00395$. This implies that in Baldwin (1999)’s setup a life expectancy of less than approximately 250 years prevents any agglomerative tendencies.

Figure 5: ϕ_{break1} (dashed) and ϕ_{break2} (solid) as a function of μ

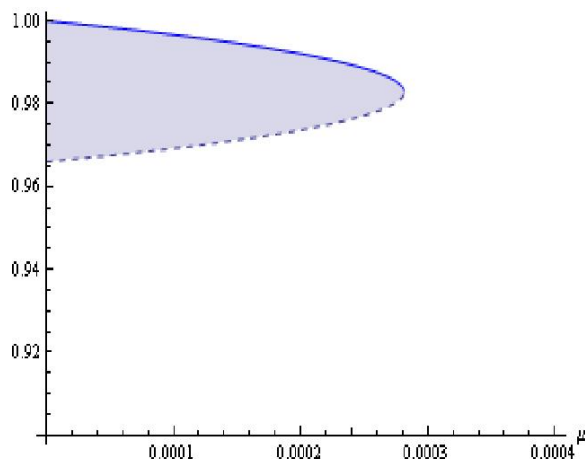

mortality rate but also reveals an interesting feature of the instability set with respect to the level of trade costs: for low but positive mortality rates, the instability set is non-monotone in ϕ implying that agglomeration processes only set in for an intermediate range of trade costs and that the symmetric equilibrium gets stable again for sufficiently high levels of economic integration. This is reflected by ϕ_{break2} being smaller than one which contrasts with Baldwin (1999)'s set-up where ϕ_{break2} is always equal to one and the symmetric equilibrium is thus unstable for all values of ϕ beyond ϕ_{break1} (see figure 5 for $\mu=0$).³² The reason for this distinctive feature of the instability region becomes clear in the next section when looking at the forces weakening or fostering agglomeration in our model. As it turns out, such informal stability will moreover be useful for developing some economic intuition about the relationship between aging and agglomeration, i.e. for understanding the channel through which the mortality rate impacts upon the stability properties of the symmetric equilibrium.

4.3 Economic intuition

As shown by Baldwin (1999), the formal stability analysis pursued in section 4.1 yields the same results as a more informal way of checking the stability

³²Figure 3 also illustrates that eigenvalue 3 is positive for all $\phi > \phi_{break1}$ in the case of $\mu = 0$.

of the symmetric equilibrium. This informal way is based on investigating how an exogenous perturbation of the home share of capital, θ_K , influences the profitability of home-based firms relative to foreign-based firms. A positive impact implies instability as even more firms would locate in the home region, i.e. capital accumulation would set in.

We can isolate three channels via which production shifting influences the relative profitability of home-based firms. First, there is a pro-agglomerative demand-linked circular causality effect. A higher capital share increases capital income in the home region and thus its expenditure share. The associated increased market size positively affects home profitability (see section 2.4.2) and therefore causes further production shifting.³³ The second channel is based on the anti-agglomerative local competition effect capturing the negative impact of production shifting upon equilibrium profits due to the more severe competition among home-based firms (see again section 2.4.2). Both these forces are present in Baldwin (1999)'s constructed capital model and explain why agglomeration in this framework sets in for sufficiently high levels of economic integration.

In our model, there appears, however, an additional dispersion force strengthening the stability of the symmetric equilibrium. In particular, the introduction of finite planning horizons motivates the anti-agglomerative turnover effect as a third channel via which production shifting changes the profitability of home-based firms. This dispersion force is based on the distributional effects caused by the turnover of generations. An exogenous rise in the home capital share increases wealth and thus expenditure levels of individuals being currently alive in the home region relative to foreign-based individuals. The negative distributional effects on aggregate expenditures resulting from death, i.e. the replacement of these individuals by newborns whose consumption expenditures are lower since they have zero wealth levels (see section 2.3), are thus more pronounced in the home region. This, in turn, decreases the home expenditure share and therefore relative profitability. Since a higher mortality rate increases the strength of

³³This agglomeration force was first introduced by Baldwin (1999) and is due to the endogeneity of capital in his model. It hinges critically on the immobility of capital as only in this case capital income cannot be repatriated to its immobile owners and therefore increases the region's own income. In our model with capital immobility it is, however, indeed the case that the equilibrium value of the consumption expenditure share depends, via this income effect, on the capital stock.

the anti-agglomerative turnover effect, this third channel intuitively explains the positive impact of μ on the stability of the symmetric equilibrium. We can thus conclude that generalizing the constructed capital model to allow for aging introduces an additional dispersion force that crucially depends on the heterogeneity of individuals with respect to their expenditure and wealth levels: as long as the consumption expenditures of newborns are smaller than average consumption expenditures, the turnover effect is active and the associated distributional effects due to death work against agglomeration.

Going back to figure 5, we are now able to explain the non-monotonicity of the instability set with respect to the level of trade costs. From figure 3 it is evident that the relative strength of the agglomeration force, as represented by eigenvalue 3, is maximized for $\phi < 1$. This is also the case for Baldwin (1999)'s set-up with a zero mortality rate. In particular, both the local competition and the agglomeration force present in the constructed capital model decrease in the level of trade costs. The local competition effect diminishes since freer trade makes firms less dependent on the home market, whereas the demand-linked circular causality effect is reduced as local sales increasingly lose importance. Both forces, however, diminish at different speeds with the competition force being reduced more rapidly for high levels of trade costs whereas the decrease of the agglomeration force is stronger for sufficiently low levels of trade barriers. This implies that the relative strength of the agglomeration force is largest for an intermediate level of trade costs. Since eigenvalue 3 remains positive and the symmetric equilibrium thus unstable for all $\phi > \phi_{break1}$ (see eigenvalue 3 for $\mu = 0$ in figure 3), this special feature does not have any consequences for the instability set in the case of a zero mortality rate. The introduction of finite horizons, however, additionally decreases eigenvalue 3 for all levels of trade costs due to the anti-agglomerative turnover effect. For $\mu > 0$, the non-monotonicity of the relative strength of the agglomeration force therefore qualitatively changes the stability properties of the symmetric equilibrium: as shown in figure 5, ϕ_{break1} increases and ϕ_{break2} decreases below one implying that the symmetric equilibrium retains its stability for sufficiently high levels of trade openness. The emergence of an additional dispersion force, when allowing for finite planning horizons, thus explains the non-monotonicity of the instability set with respect to the level of economic integration in the case of a positive mortality rate.

5 Concluding remarks

The model in this paper introduces demography into the New Economic Geography by generalizing the constructed capital framework of Baldwin (1999) to account for changes in the age structure of the population. Incorporating finite individual planning horizons allows us to investigate the impacts of population aging on agglomeration tendencies of economic activities. We show that the introduction of mortality stabilizes the symmetric equilibrium and thus acts as a force that promotes a more equal distribution of productive factors between two regions.

From the point of view of economic policy, we can conclude that, in sharp contrast to other New Economic Geography approaches, our model does not necessarily associate sufficiently deep integration with high interregional inequality. In particular, we have shown that plausible mortality rates are far away from supporting agglomeration processes. Consequently, there is no need to impose any type of trade barriers in order to avoid deindustrialization of one region resulting from decreased transport costs. Especially in the case of the European Union this implies that there is no tradeoff between its two most important targets: integration on the one hand and interregional equality on the other hand. Instead, the implementation of appropriate policies to achieve one objective does not interfere with the realization of the other goal.

However, introducing mortality was only a first step towards a more comprehensive understanding of the interrelations between aging, economic integration and agglomeration. The assumption of a constant mortality rate adopted for the sake of analytical tractability is still at odds with reality. Using age dependent mortality rates is therefore one possible line for future research. Similarly, investigating the effects of age dependent labor productivity on agglomeration processes might yield important insights, especially when viewing labor productivity as decisive for a region's competitiveness. Moreover, it would be worthwhile to consider asymmetric regions, in particular with respect to mortality. In such a setting one could investigate how differences in mortality rates are linked to differences in capital accumulation rates, again a question of high relevance for economic policy.

Acknowledgements

We thank Dalkhat Ediev (Vienna Institute of Demography), Ingrid Kubin (Vienna University of Economics and Business Administration), Alexia Prskawetz (Vienna University of Technology), Gerhard Orosel (University of Vienna), Gerhard Sorger (University of Vienna), Jens Südekum (University of Duisburg-Essen), Vladimir Veliov (Vienna University of Technology), Stefan Wrzaczek (Vienna University of Technology), and the conference participants at the RIEF Doctoral Meeting 2009, at the Annual Meeting of the Austrian Economic Association 2009 and at the ERSA Congress 2009 as well as the seminar participants at the Institute for Advanced Studies, the University of Vienna, the Vienna University of Economics and Business and the Vienna Institute for International Economics Studies for helpful comments and suggestions. The paper was prepared within the research project “Agglomeration processes in aging societies” funded by the Vienna Science and Technology Fund (WWTF) in its “Mathematics and... Call” 2007.

Appendix

A The individual's utility optimization problem

Suppressing time arguments in the optimization procedure, the current value Hamiltonian for the individual's optimization problem is

$$H(e, k, \lambda, t) = \ln \left[\frac{e}{P} \right] + \lambda \left(\frac{wl + \pi k - e}{wF} + \mu k - \delta k \right) \quad (36)$$

where P is the perfect price index translating expenditures into indirect utility.³⁴ The first order conditions of the problem associated with equation (36) are given by

$$\frac{\partial H}{\partial e} \stackrel{!}{=} 0 \Rightarrow \frac{1}{e} = \frac{\lambda}{Fw}, \quad (37)$$

$$\frac{\partial H}{\partial k} \stackrel{!}{=} (\rho + \mu)\lambda - \dot{\lambda} \Rightarrow \frac{\dot{\lambda}}{\lambda} = -\frac{\pi}{Fw} + \rho + \delta, \quad (38)$$

$$\frac{\partial H}{\partial \lambda} \stackrel{!}{=} \dot{k} \Rightarrow \frac{wl + \pi k - e}{wF} + \mu k - \delta k = \dot{k} \quad (39)$$

and the standard transversality condition. Taking the time derivative of equation (37) under the assumption that w is time independent³⁵ and combining it with equation (38) yields the individual consumption Euler equation

$$\frac{\dot{e}}{e} = \frac{\pi}{Fw} - \delta - \rho.$$

The static problem of dividing consumption between the manufacturing composite and the agricultural good for fixed consumption expenditure e can be formulated as

$$\begin{aligned} & \max_{c_m^{agg}, c_n} (c_n)^{1-\xi} (c_m^{agg})^\xi \\ \text{s.t. } & p_n c_n + p_m^{agg} c_m^{agg} = e, \end{aligned} \quad (40)$$

where p_m^{agg} is an appropriate price index which can be shown to equal a weighted average of the two Dixit and Stiglitz (1977) price indexes at home and foreign with the foreign price index being augmented by transport costs.

³⁴This price index can be obtained from the solution to the optimization problem in stage two and three.

³⁵Section 2.4.1 shows that this indeed holds as the wage rate is pinned down by the price of the agricultural good which is chosen to be the numeraire of the economy.

Setting up the Lagrangian

$$\ell(c_n, c_m^{agg}, \lambda_a) = (c_n)^{1-\xi} (c_m^{agg})^\xi + \lambda_a (e - p_n c_n - p_m^{agg} c_m^{agg}) \quad (41)$$

and solving for the first order conditions yields

$$\frac{\partial \ell}{\partial c_n} \stackrel{!}{=} 0 \Rightarrow (1-\xi)(c_n)^{-\xi} (c_m^{agg})^\xi = \lambda_a p_n, \quad (42)$$

$$\frac{\partial \ell}{\partial c_m^{agg}} \stackrel{!}{=} 0 \Rightarrow (c_n)^{1-\xi} \xi (c_m^{agg})^{\xi-1} = \lambda_a p_m^{agg}, \quad (43)$$

$$\frac{\partial \ell}{\partial \lambda_a} \stackrel{!}{=} 0 \Rightarrow p_n c_n + p_m^{agg} c_m^{agg} = e. \quad (44)$$

Manipulating these first order conditions leads to unit elastic demands for the agricultural good and the CES composite of manufactured varieties given by

$$\begin{aligned} c_n &= \frac{(1-\xi)e}{p_n} \\ c_m^{agg} &= \frac{\xi e}{p_m^{agg}}. \end{aligned} \quad (45)$$

Due to the Cobb-Douglas specification of utility, a fraction ξ of income used for consumption is spent on manufactures and a fraction $1-\xi$ on the agricultural good.

In the last stage, the static problem of distributing manufacturing consumption among different varieties for fixed manufacturing consumption expenditure ξe can be formulated as

$$\begin{aligned} \max_{c_m^H(i), c_m^F(j)} & \left[\int_0^{V_H} (c_m^H(i))^{\frac{\sigma-1}{\sigma}} di + \int_0^{V_F} (c_m^F(j))^{\frac{\sigma-1}{\sigma}} dj \right]^{\frac{\sigma}{\sigma-1}} \\ \text{s.t.} & \int_0^{V_H} p_m^H(i) c_m^H(i) di + \int_0^{V_F} p_{m,\varphi}^F(j) c_m^F(j) dj = \xi e. \end{aligned} \quad (46)$$

Setting up the Lagrangian

$$\begin{aligned} \ell(c_m^H(i), c_m^F(j), \lambda_m) &= \left[\int_0^{V_H} (c_m^H(i))^{\frac{\sigma-1}{\sigma}} di + \int_0^{V_F} (c_m^F(j))^{\frac{\sigma-1}{\sigma}} dj \right]^{\frac{\sigma}{\sigma-1}} + \\ & \lambda_m \left[\xi e - \int_0^{V_H} p_m^H(i) c_m^H(i) di - \int_0^{V_F} p_{m,\varphi}^F(j) c_m^F(j) dj \right] \end{aligned} \quad (47)$$

and solving for the first order conditions yields³⁶

$$\begin{aligned} \frac{\partial \ell}{\partial c_m^H(i)} \stackrel{!}{=} 0 \Rightarrow & \frac{\sigma}{\sigma-1} \left[\int_0^{V_H} (c_m^H(i))^{\frac{\sigma-1}{\sigma}} di + \int_0^{V_F} (c_m^F(j))^{\frac{\sigma-1}{\sigma}} dj \right]^{\frac{1}{\sigma-1}} \\ & \times \frac{\sigma-1}{\sigma} (c_m^H(i))^{-\frac{1}{\sigma}} = \lambda_m p_m^H(i), \end{aligned} \quad (48)$$

$$\begin{aligned} \frac{\partial \ell}{\partial c_m^F(j)} \stackrel{!}{=} 0 \Rightarrow & \frac{\sigma}{\sigma-1} \left[\int_0^{V_H} (c_m^H(i))^{\frac{\sigma-1}{\sigma}} di + \int_0^{V_F} (c_m^F(j))^{\frac{\sigma-1}{\sigma}} dj \right]^{\frac{1}{\sigma-1}} \\ & \times \frac{\sigma-1}{\sigma} (c_m^F(j))^{-\frac{1}{\sigma}} = \lambda_m p_{m,\varphi}^F(j), \end{aligned} \quad (49)$$

$$\frac{\partial \ell}{\partial \lambda_m} \stackrel{!}{=} 0 \Rightarrow \int_0^{V_H} p_m^H(i) c_m^H(i) di + \int_0^{V_F} p_{m,\varphi}^F(j) c_m^F(j) dj = \xi e. \quad (50)$$

Recalling the definition of c_m^{agg} given below equation (1), these first order conditions can be rewritten as

$$c_m^{agg} \left[\int_0^{V_H} (c_m^H(i))^{\frac{\sigma-1}{\sigma}} di + \int_0^{V_F} (c_m^F(j))^{\frac{\sigma-1}{\sigma}} dj \right]^{-1} (c_m^H(i))^{-\frac{1}{\sigma}} = \lambda_m p_m^H(i), \quad (51)$$

$$c_m^{agg} \left[\int_0^{V_H} (c_m^H(i))^{\frac{\sigma-1}{\sigma}} di + \int_0^{V_F} (c_m^F(j))^{\frac{\sigma-1}{\sigma}} dj \right]^{-1} (c_m^F(j))^{-\frac{1}{\sigma}} = \lambda_m p_{m,\varphi}^F(j). \quad (52)$$

Isolating $c_m^H(i)$ and $c_m^F(j)$ on the left hand side, then multiplying both sides by $p_m^H(i)$ or $p_{m,\varphi}^F(j)$ and finally integrating over all varieties yields

$$\begin{aligned} & \int_0^{V_H} p_m^H(i) c_m^H(i) di = \\ & \frac{\lambda_m^{-\sigma} \int_0^{V_H} (p_m^H(i))^{1-\sigma} di \left[\int_0^{V_H} (c_m^H(i))^{\frac{\sigma-1}{\sigma}} di + \int_0^{V_F} (c_m^F(j))^{\frac{\sigma-1}{\sigma}} dj \right]^{-\sigma}}{(c_m^{agg})^{-\sigma}}, \\ & \int_0^{V_F} p_{m,\varphi}^F(j) c_m^F(j) dj = \\ & \frac{\lambda_m^{-\sigma} \int_0^{V_F} (p_{m,\varphi}^F(j))^{1-\sigma} dj \left[\int_0^{V_H} (c_m^H(i))^{\frac{\sigma-1}{\sigma}} di + \int_0^{V_F} (c_m^F(j))^{\frac{\sigma-1}{\sigma}} dj \right]^{-\sigma}}{(c_m^{agg})^{-\sigma}}. \end{aligned}$$

Adding these two expressions, using the budget constraint from above, and

³⁶Note that this is in fact a variational problem.

isolating λ_m gives the Lagrange multiplier

$$\lambda_m = \frac{(\xi e)^{-\frac{1}{\sigma}} c_m^{agg} \left[\int_0^{V_H} (p_m^H(i))^{1-\sigma} di + \int_0^{V_F} (p_{m,\varphi}^F(j))^{1-\sigma} dj \right]^{\frac{1}{\sigma}}}{\left[\int_0^{V_H} (c_m^H(i))^{\frac{\sigma-1}{\sigma}} di + \int_0^{V_F} (c_m^F(j))^{\frac{\sigma-1}{\sigma}} dj \right]}, \quad (53)$$

i.e. the shadow price of manufacturing consumption. Plugging this expression back into equations (51) and (52) finally leads to the demands for all varieties

$$c_m^H(i) = \frac{\xi e (p_m^H(i))^{-\sigma}}{\left[\int_0^{V_H} (p_m^H(i))^{1-\sigma} di + \int_0^{V_F} (p_{m,\varphi}^F(j))^{1-\sigma} dj \right]},$$

$$c_m^F(j) = \frac{\xi e (p_{m,\varphi}^F(j))^{-\sigma}}{\left[\int_0^{V_H} (p_m^H(i))^{1-\sigma} di + \int_0^{V_F} (p_{m,\varphi}^F(j))^{1-\sigma} dj \right]}.$$

B Aggregation over individuals

Following Heijdra and van der Ploeg (2002), chapter 16, the aggregate Euler equation can be derived as follows. Taking the time derivative of aggregate consumption expenditures defined in equation (9) yields

$$\begin{aligned} \dot{E}(t) &= \mu e(t, t) + \mu \int_{-\infty}^t \dot{e}(t_0, t) e^{-\mu(t-t_0)} + e(t_0, t) (-\mu) e^{-\mu(t-t_0)} dt_0 \\ &= \mu e(t, t) - \mu E(t) + \mu \int_{-\infty}^t \dot{e}(t_0, t) e^{-\mu(t-t_0)} dt_0, \end{aligned} \quad (54)$$

where we used again the definition of aggregate consumption expenditures in going from the first to the second line. To arrive at the final aggregate Euler equation it is necessary to derive optimal consumption expenditures $e(t, t)$ of newborns in the planning period t and the aggregate consumption expenditure rule $E(t)$. To achieve this, we reformulate the individual's optimization problem as follows. In line with equation (1) the expected utility $U(t_0, t)$ at an arbitrary point in time t of a consumer born at time $t_0 \leq t$ is given by

$$U(t_0, t) \equiv \int_t^{\infty} e^{-(\rho+\mu)(\tau-t)} \ln \left(\frac{e(t_0, \tau)}{P(\tau)} \right) d\tau, \quad (55)$$

where we again used the perfect price index P translating expenditures in indirect utility (see appendix A). The law of motion of capital given in

equation (2) can be rewritten as

$$\begin{aligned}\dot{k}(t_0, \tau) &= \frac{w(\tau)l(\tau) + \pi(\tau)k(t_0, \tau) - e(t_0, \tau)}{w(\tau)F} + \mu k(t_0, \tau) - \delta k(t_0, \tau) \\ &= \left(\frac{\pi(\tau)}{w(\tau)F} + \mu - \delta \right) k(t_0, \tau) + \frac{l(\tau)}{F} - \frac{e(t_0, \tau)}{w(\tau)F}.\end{aligned}\quad (56)$$

From equation (56) the individual's lifetime budget can be derived. First both sides of the equation are multiplied by $e^{-R^A(t, \tau)} \equiv e^{-\int_t^\tau \left(\frac{\pi(s)}{w(s)F} + \mu - \delta \right) ds}$ and rearranged to

$$\left[\dot{k}(t_0, \tau) - \left(\frac{\pi(\tau)}{w(\tau)F} + \mu - \delta \right) k(t_0, \tau) \right] e^{-R^A(t, \tau)} = \left[\frac{l(\tau)}{F} - \frac{e(t_0, \tau)}{w(\tau)F} \right] e^{-R^A(t, \tau)}.\quad (57)$$

Observing that the left hand side of equation (57) is $d \left[k(t_0, \tau) e^{-R^A(t, \tau)} \right] / d\tau$ by applying Leibnitz's rule to recognize that $dR^A(t, \tau) / d\tau = \frac{\pi(\tau)}{w(\tau)F} + \mu - \delta$ and integrating over the interval $[t, \infty)$ yields

$$\int_t^\infty d \left[k(t_0, \tau) e^{-R^A(t, \tau)} \right] = \int_t^\infty \left[\frac{l(\tau)}{F} - \frac{e(t_0, \tau)}{w(\tau)F} \right] e^{-R^A(t, \tau)} d\tau.$$

This expression can be solved to

$$\lim_{\tau \rightarrow \infty} k(t_0, \tau) e^{-R^A(t, \tau)} - k(t_0, t) e^{-R^A(t, t)} = HW(t) - \int_t^\infty \frac{e(t_0, \tau)}{w(\tau)F} e^{-R^A(t, \tau)} d\tau,\quad (58)$$

where $HW(t) \equiv \int_t^\infty \frac{w(\tau)l(\tau)}{w(\tau)F} e^{-R^A(t, \tau)} d\tau$ denotes human wealth of individuals in capital units consisting of the present value of lifetime wage income using the annuity factor $R^A(t, \tau)$ for discounting. Note that $e^{-R^A(t, t)} = 1$ and that the first term on the left hand side represents "terminal capital holdings". These holdings must be equal to zero because first, the insurance company will ensure their nonnegativity, and second, it is suboptimal for an individual to have positive terminal assets as there is neither a bequest motive nor satiation from consumption. Taking this into account, yields the following solvency condition

$$\lim_{\tau \rightarrow \infty} e^{-R^A(t, \tau)} k(t_0, \tau) = 0,\quad (59)$$

which prevents an individual from running a Ponzi game against the life-insurance company. The No-Ponzi-Game condition can be inserted in equa-

tion (58) to obtain the individual's lifetime budget restriction

$$k(t_0, t) + HW(t) = \int_t^\infty \frac{e(t_0, \tau)}{w(\tau)F} e^{-R^A(t, \tau)} d\tau. \quad (60)$$

The present value of an individual's consumption expenditure plan in capital units must be equal to the sum of human wealth in capital units and capital holdings (=total wealth). Evaluating the lifetime budget constraint at $t = t_0$ shows that the discounted sum of lifetime labor earnings must equal discounted consumption expenditures.³⁷ This implies, from investigating the law of motion for capital, that discounted savings are equal to discounted accumulated profits, i.e. savings are only used for reallocating consumption across lifetime.

Maximizing expected utility given in equation (55) subject to the budget constraint in equation (60) yields the following first order condition

$$\frac{1}{e(t_0, \tau)} e^{-(\rho+\mu)(\tau-t)} = \lambda(t) \frac{1}{w(\tau)F} e^{-R^A(t, \tau)}, \quad \tau \in [t, \infty), \quad (61)$$

where $\lambda(t)$ represents the marginal expected lifetime utility of wealth.³⁸ Individuals should therefore plan consumption expenditures in a way such that the appropriately discounted marginal utility of expenditures and wealth are equated.

Applying equation (61) for the planning period ($\tau = t$) yields $e(t_0, t) = \frac{w(t)F}{\lambda(t)}$. Using this result and then substituting for $\lambda(t)$ also from the first order condition in equation (61) helps to establish the following equality

$$\begin{aligned} \int_t^\infty e(t_0, t) e^{-(\rho+\mu)(\tau-t)} d\tau &= \int_t^\infty \frac{w(t)F}{\lambda(t)} e^{-(\rho+\mu)(\tau-t)} d\tau \\ &= Fw(t) \int_t^\infty \frac{e(t_0, \tau)}{Fw(\tau)} e^{-R^A(t, \tau)} d\tau. \end{aligned}$$

Integrating out and using the lifetime budget constraint of equation (60)

³⁷Recall that capital holdings of newborns $k(t_0, t_0)$ are zero by assumption (no bequests).

³⁸Differentiating this first order condition with respect to τ , inserting the expression for $\lambda(t)$ also obtainable from this first order condition and simplifying yields the following Euler equation

$$\frac{\dot{e}(t_0, \tau)}{e(t_0, \tau)} = \frac{\pi(\tau)}{w(\tau)F} - \rho - \delta + \frac{\dot{w}(\tau)}{w(\tau)}. \quad (62)$$

With time-invariant wages (see section 2.4.1), this Euler equation is exactly the same as the one obtained in equation (6).

finally yields consumption expenditures $e(t_0, t)$ in the planning period t

$$\begin{aligned} \frac{e(t_0, t)}{\rho + \mu} \left[-e^{-(\rho + \mu)(\tau - t)} \right]_t^\infty &= Fw(t)[k(t_0, t) + HW(t)] \\ e(t_0, t) &= (\rho + \mu)Fw(t)[k(t_0, t) + HW(t)]. \end{aligned} \quad (63)$$

The above equation clearly shows that optimal consumption expenditures in the planning period t in capital units, $\frac{e(t_0, t)}{Fw(t)}$, are proportional to total wealth with the marginal propensity to consume out of total wealth being constant and equal to the effective rate of time preference $\rho + \mu$.

Using this expression for optimal consumption expenditures in the definition of aggregate consumption expenditures in equation (9) yields the following very simple aggregate consumption expenditure rule

$$\begin{aligned} E(t) &\equiv \mu \int_{-\infty}^t e^{-\mu(t-t_0)} (\rho + \mu) Fw(t) [k(t_0, t) + HW(t)] dt_0 \\ &= (\rho + \mu) Fw(t) \mu \left[\int_{-\infty}^t e^{-\mu(t-t_0)} k(t_0, t) dt_0 + \int_{-\infty}^t e^{-\mu(t-t_0)} HW(t) dt_0 \right] \\ &= (\rho + \mu) Fw(t) [K(t) + HW(t)], \end{aligned} \quad (64)$$

where the aggregate capital stock is defined in equation (7) and can be rewritten in analogy to aggregate consumption expenditures in equation (9). Moreover it is easily established that $\mu HW(t) \left[\frac{e^{-\mu(t-t_0)}}{\mu} \right]_{-\infty}^t = HW(t)$.³⁹

Finally we modify equation (54) by substituting for $e(t, t)$ and $E(t)$ from the derived expressions of equation (63) evaluated at birth date t ⁴⁰ and equation (64) as well as for $\dot{e}(t_0, t)$ from the individual Euler equation given

³⁹This aggregation property of consumption expenditures is due to the fact that we assume a constant probability of death implying an age independent marginal propensity to consume out of total wealth (see equation (63)).

⁴⁰Note again that $k(t, t) = 0$ and newborns therefore consume a fraction of their human wealth at birth, i.e. $e(t, t) = (\rho + \mu)Fw(t)HW(t)$.

in expression (62). Dividing by $E(t)$ then gives the aggregate Euler equation

$$\begin{aligned}
\frac{\dot{E}(t)}{E(t)} &= -\mu(\rho + \mu)Fw(t)\frac{K(t)}{E(t)} + \\
&\quad \frac{\mu}{E(t)} \int_{-\infty}^t e(t_0, t) \left[\frac{\pi(t)}{w(t)F} - \rho - \delta + \frac{\dot{w}(t)}{w(t)} \right] e^{-\mu(t-t_0)} dt_0 \\
&= -\mu(\rho + \mu)Fw(t)\frac{K(t)}{E(t)} + \frac{\pi(t)}{w(t)F} - \rho - \delta + \frac{\dot{w}(t)}{w(t)} \\
&= -\mu \frac{E(t) - e(t, t)}{E(t)} + \frac{\dot{e}(t_0, t)}{e(t_0, t)},
\end{aligned}$$

where in the third line we used again the definition of aggregate consumption expenditure from equation (9) and the term $\dot{w}(t)/w(t)$ disappears in the case of time invariant wages (see section 2.4.1).

C The manufacturing firm's profit maximization problem - Derivation of rental rates

By substituting for optimal demands for varieties from the constraints of the maximization problem as stated in equation 18, operating profit can be rewritten as

$$\begin{aligned}
&(p_m^H(i, t) - w(t)\beta) \left(\int_{-\infty}^t \frac{\xi e(t_0, t)(p_m^H(i, t))^{-\sigma}}{P_m(t)} N(t_0, t) dt_0 \right) + \\
&(p_{m,\varphi}^F(i, t) - w(t)\varphi\beta) \left(\int_{-\infty}^t \frac{\xi e^*(t_0, t)(p_{m,\varphi}^F(i, t))^{-\sigma}}{P_m^*(t)} N^*(t_0, t) dt_0 \right),
\end{aligned} \tag{65}$$

whose derivatives with respect to $p_m^H(i, t)$ and $p_{m,\varphi}^F(i, t)$ are set equal to zero to yield the first order conditions

$$\frac{\int_{-\infty}^t \xi e(t_0, t) N(t_0, t) dt_0}{P_m(t)} [(1 - \sigma)(p_m^H(i, t))^{-\sigma} + \sigma w(t)\beta(p_m^H(i, t))^{-\sigma-1}] = 0,$$

$$\frac{\int_{-\infty}^t \xi e^*(t_0, t) N^*(t_0, t) dt_0}{P_m^*(t)} [(1 - \sigma)(p_{m,\varphi}^F(i, t))^{-\sigma} + \sigma w(t)\beta\varphi(p_{m,\varphi}^F(i, t))^{-\sigma-1}] = 0.$$

Rearranging and simplifying gives optimal prices

$$\begin{aligned} p_m^H(i, t) &= \frac{\sigma}{\sigma - 1} w(t) \beta, \\ p_{m, \varphi}^F(i, t) &= \frac{\sigma}{\sigma - 1} w(t) \beta \varphi. \end{aligned}$$

Using these pricing rules and the definition of aggregate expenditures given in equation 8 in equation 65 and simplifying yields operating profits as

$$\pi(t) = \frac{\xi E(t)}{\sigma(K(t) + \varphi^{1-\sigma} K^*(t))} + \frac{\xi \varphi^{1-\sigma} E^*(t)}{\sigma(\varphi^{1-\sigma} K(t) + K^*(t))} \quad (66)$$

where an equivalent equation holds in the foreign region. Note that the number of varieties in the home region $V_H(t)$ is equal to the capital stock at home $K(t)$ as one variety exactly requires one unit of capital as fixed input (analogously $K^*(t) \equiv V_F(t)$) and that the variety index i can be dropped since prices and therefore profits are equal for all firms. Applying the definitions of regional share variables and global quantities as well as the definition of openness yields the final expressions for regional rental rates⁴¹

$$\begin{aligned} \pi &= \underbrace{\left(\frac{\theta_E}{\theta_K + \phi(1 - \theta_K)} + \frac{(1 - \theta_E)\phi}{\phi\theta_K + 1 - \theta_K} \right)}_{Bias} \left(\frac{\xi E^W}{\sigma K^W} \right), \\ \pi^* &= \underbrace{\left(\frac{1 - \theta_E}{1 - \theta_K + \phi\theta_K} + \frac{\theta_E\phi}{\phi(1 - \theta_K) + \theta_K} \right)}_{Bias^*} \left(\frac{\xi E^W}{\sigma K^W} \right). \end{aligned}$$

⁴¹We ignore time arguments here.

D Intermediate results for the stability analysis

The Jacobian matrix J_{sym} , which is evaluated at the symmetric equilibrium and given in equation 30, has the following entries J_i for $i = 1, \dots, 4$:

$$J_1 = \frac{1}{2(\phi+1)\sqrt{\sigma}} \begin{pmatrix} A(\phi+2) - B\phi & (A+B)\phi \\ (A+B)\phi & A(\phi+2) - B\phi \end{pmatrix}, \quad (67)$$

$$J_2 = \begin{pmatrix} \frac{-F(A+B)^2(\phi^2+1)}{4(\phi+1)^2\xi} - F\mu(\mu+\rho) & -\frac{(A+B)^2F\phi}{2(\phi+1)^2\xi} \\ -\frac{(A+B)^2F\phi}{2(\phi+1)^2\xi} & \frac{-F(A+B)^2(\phi^2+1)}{4(\phi+1)^2\xi} - F\mu(\mu+\rho) \end{pmatrix}, \quad (68)$$

$$J_3 = \frac{1}{F(\phi+1)\sigma} \begin{pmatrix} \xi - (\phi+1)\sigma & \phi\xi \\ \phi\xi & \xi - (\phi+1)\sigma \end{pmatrix}, \quad (69)$$

$$J_4 = \begin{pmatrix} \frac{\phi(A+\rho\sqrt{\sigma}) - \delta(\phi^2+\phi+1)\sqrt{\sigma}}{(\phi+1)^2\sqrt{\sigma}} & -\frac{(A+B)\phi}{(\phi+1)^2\sqrt{\sigma}} \\ -\frac{(A+B)\phi}{(\phi+1)^2\sqrt{\sigma}} & \frac{\phi(A+\rho\sqrt{\sigma}) - \delta(\phi^2+\phi+1)\sqrt{\sigma}}{(\phi+1)^2\sqrt{\sigma}} \end{pmatrix}, \quad (70)$$

with the parameter clusters $A \equiv \sqrt{\sigma(\delta + \rho)^2 + 4\mu(\mu + \rho)\xi}$ as well as $B \equiv (\delta + \rho)\sqrt{\sigma}$.

In order to get a first insight into the nature and signs of the eigenvalues of J_{sym} , we calibrated the model using the parameter values $\rho = 0.015$ and $\delta = 0.05$ and allowing the elasticity of substitution and the manufacturing share of consumption to vary within the ranges $2 \leq \sigma \leq 8$ and $0.1 \leq \xi \leq 0.9$. Figures 6, 7, 8 and 9 illustrate the numerical investigation of the signs of the eigenvalues for $\sigma = 4$, $\xi = 0.3$ and varying μ and ϕ .⁴²

First, the figures suggest that all eigenvalues are real for the chosen parameter space. Moreover, figures 6, 7 and 9 show that the first eigenvalue is always negative, whereas the second and fourth are always positive. This result is independent of the level of transport costs and the mortality rate. Saddle path stability of the symmetric equilibrium therefore seems to crucially depend on the third eigenvalue by requiring it to be negative. As can be seen from the 3D plot in figure 8 there only exists a very small range of combinations of low μ and high ϕ where the sign of the third eigenvalue is positive. One is therefore tempted to conclude that with a sufficiently high mortality rate, the symmetric equilibrium is stable for all levels of transport costs.

⁴²We also conducted the same simulations for other values of σ and ξ within the considered range. Overall, we find that our findings with respect to the signs of the eigenvalues are insensitive to changes in those parameters.

Figure 6: **Eigenvalue 1**

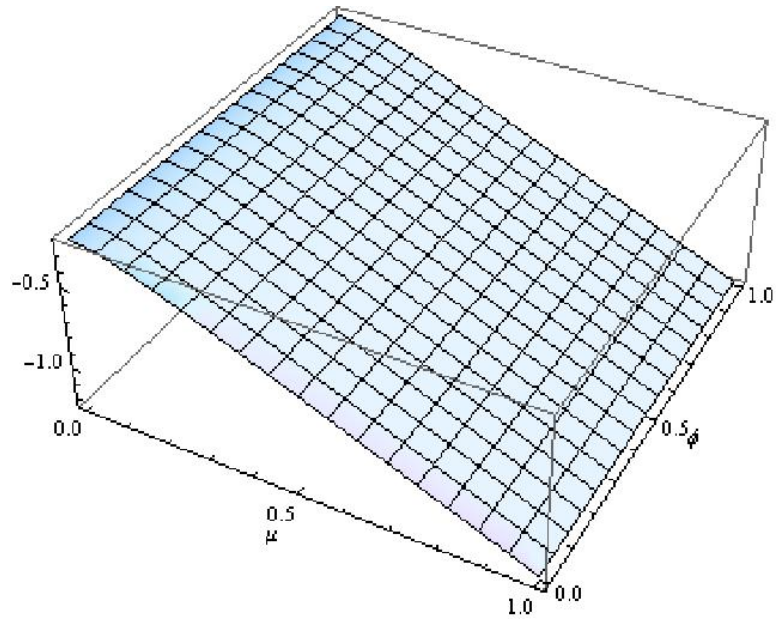

Figure 7: **Eigenvalue 2**

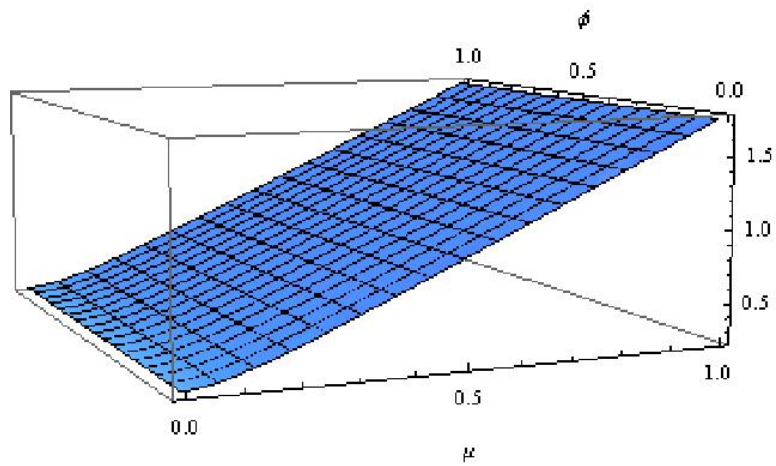

Figure 8: **Eigenvalue 3**

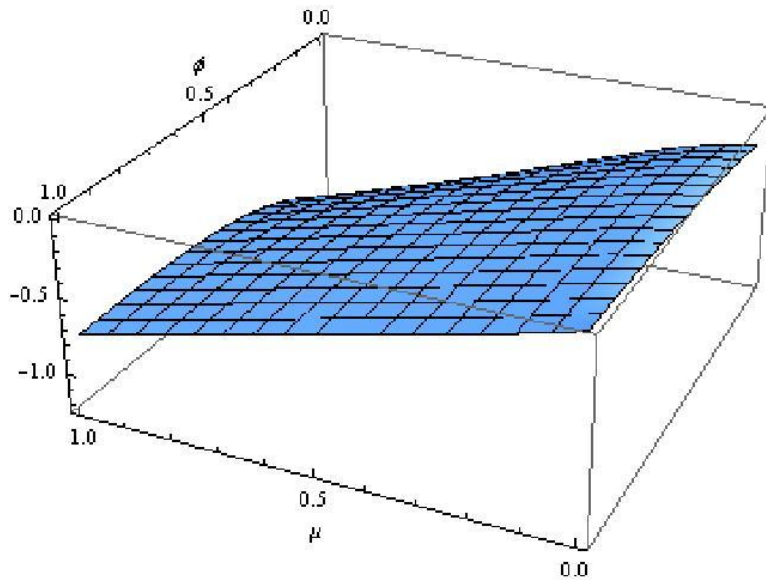
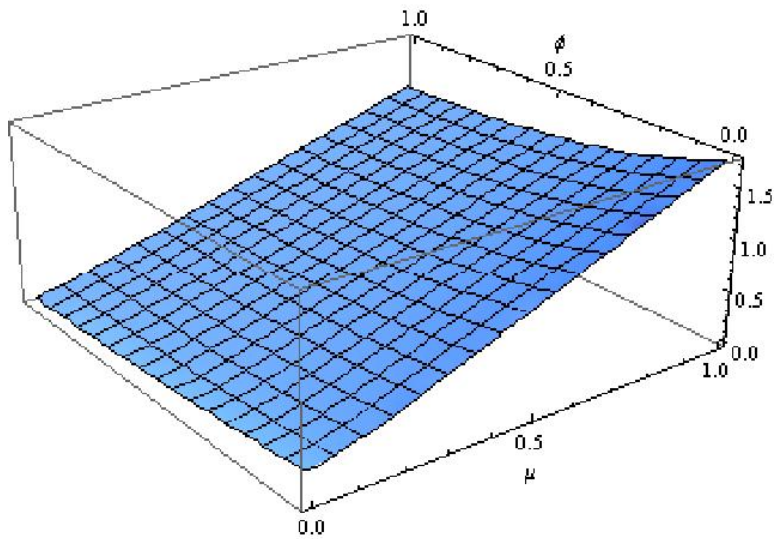

Figure 9: **Eigenvalue 4**



References

- Auerbach, A. J. and Kotlikoff, L. J. (1987). *Dynamic Fiscal Policy*. Cambridge University Press.
- Baldwin, R., Forslid, R., Martin, P., Ottaviano, G., and Robert-Nicoud, F. (2003). *Economic Geography & Public Policy*. Princeton University Press.
- Baldwin, R. E. (1999). Agglomeration and endogenous capital. *European Economic Review*, Vol. 43(No. 2):253–280.
- Barro, R. J. and Sala-i-Martin, X. S. (2004). *Economic Growth*. MIT Press.
- Blanchard, O. J. (1985). Debt, deficits and finite horizons. *Journal of Political Economy*, Vol. 93(No. 2):223–247.
- Bosker, M. and Garretsen, H. (2007). Trade costs, market access and economic geography: Why the empirical specification of trade costs matters. *CEPR Discussion Paper 2071*, pages 1–41.
- Brakman, S., Garretsen, H., and Schramm, M. (2005). Putting the new economic geography to the test: Free-ness of trade and agglomeration in the EU regions. *CESifo Working Paper No. 1566*, pages 1–38.
- Dixit, A. K. and Stiglitz, J. E. (1977). Monopolistic competition and optimum product diversity. *American Economic Review*, Vol. 67(No. 3):297–308.
- Eurostat (2004). *Eurostat yearbook 2004: The statistical guide to Europe*. Office for Official Publications of the European Communities.
- Futagami, K. and Nakajima, T. (2001). Population aging and economic growth. *Journal of Macroeconomics*, Vol. 23(No. 1):31–44.
- Gertler, M. (1999). Government debt and social security in a life-cycle economy. *Carnegie-Rochester Conference Series on Public Policy*, Vol. 50:61–110.
- Head, K. and Mayer, T. (2003). The empirics of agglomeration and trade. *CEPR Working Papers*, pages 1–69.
- Heijdra, B. J. and van der Ploeg, F. (2002). *Foundations of Modern Macroeconomics*. Oxford University Press.

- Krugman, P. (1991). Increasing returns and economic geography. *Journal of Political Economy*, Vol. 99(No. 3):483–499.
- Krugman, P. and Venables, A. J. (1995). Globalization and the inequality of nations. *The Quarterly Journal of Economics*, Vol. 110(No. 4):857–880.
- Martin, P. and Ottaviano, G. (1999). Growing locations: Industry location in a model of endogenous growth. *European Economic Review*, Vol. 43:281–302.
- Puga, D. (1999). The rise and fall of regional inequalities. *European Economic Review*, Vol. 43:303–334.
- Ramsey, F. P. (1928). A mathematical theory of saving. *The Economic Journal*, Vol. 38(No. 152):543–559.
- Sachs, J. D. and Warner, A. (1995). Economic reform and the process of global integration. *Brookings Papers on Economic Activity*, (No. 1):1–118.
- Solow, R. M. (1956). A contribution to the theory of economic growth. *The Quarterly Journal of Economics*, Vol. 70(No. 1):65–94.
- United Nations (2007). World population prospects: The 2006 revision. Url: <http://www.un.org/esa/population/publications/wpp2006/english.pdf>.
- Venables, A. J. (1996). Equilibrium locations of vertically linked industries. *International Economic Review*, Vol. 37(No. 2):341–359.
- Yaari, M. E. (1965). Uncertain lifetime, life insurance and the theory of the consumer. *The Review of Economic Studies*, Vol. 32(No. 2):137–150.
- Zhang, J., Zhang, J., and Lee, R. (2003). Rising longevity, education, savings, and growth. *Journal of Development Economics*, Vol. 70(No. 1):83–101.